

## Request for Proposals

### *Exhibitions & Activations, Arts & Design, France (Paris)*

#### **RFP Timeline:**

- Release Date: April 15th, 2026
- Feedback on interest / participation to the competition to be received before April 22nd, 2026
- Explanation / Q&A meeting: April 27th, 2026 time TBD
- Enquiries Cut-off Date: April 30th, 2026
- Response Deadline: May 11th 2026

#### **Project Timeline:**

- Preparation: April – August, 2026
- Implementation (Deliverables Due Date): **September- October 2026**

#### **Contact Information:**

AFALULA

82, rue de Courcelles – 75008 Paris,  
France

Attn:

Simon Garcia – Director, Cultural  
Development

Arnaud Morand – Head of Arts &  
Creative Industries

And Emily Marant, Senior Design  
Consultant / Audrey Chazal – Arts &  
Creative Industries consultant

Email:

[Simon.garcia@afalula.com](mailto:Simon.garcia@afalula.com)

[arnaud.morand@afalula.com](mailto:arnaud.morand@afalula.com)

cc [audrey.chazal@external.afalula.com](mailto:audrey.chazal@external.afalula.com)

[emily.marant@external.afalula.com](mailto:emily.marant@external.afalula.com)

[a.alghazzawi@rcu.gov.sa](mailto:a.alghazzawi@rcu.gov.sa)

---

## **RFP Contents:**

### **Sections:**

1. Presentation of Entities
2. Context and description of the project
3. Overview of the deliverables
4. Timeline Overview
5. Vendor Role and Responsibility

### **Appendices:**

1. Vendor Application Dossier Requirements
2. Process and Criteria of Application Assessment
3. Commitment Form / Act of Engagement Form

## 1. Presentation of Entities

The [French Agency for the Development of AlUla](#) (Afalula – “The Client”) a simplified joint stock company whose registered office is located at 82 rue de Courcelles 75008 Paris and whose identification number is 841 021 454 RCS Paris ("AFALULA") was created following the April 2018 intergovernmental agreement between the Government of the Kingdom of Saudi Arabia and the Government of the French Republic. This agreement provides for French excellence to be associated with the project to develop and enhance the AlUla territory (Saudi Arabia) in terms of tourism, infrastructure, economy, environment, arts and culture. The aim is to develop AlUla in an innovative way and make it a leading tourist, cultural, and sustainable destination.

To achieve this, the agency is co-constructing the project with the [Royal Commission for AlUla](#) (RCU). Established in July 2017, RCU oversees the AlUla project.

This mission of Afalula includes promoting French expertise and know-how in all the fields covered by the AlUla project and in the context of this RFP, arts and culture.

## 2. Context and description of the Project

AlUla is a region of exceptional natural and cultural importance in north-western Saudi Arabia. The city is located 300 km north of Medina. A jewel of Saudi Arabia's heritage, AlUla is part of the Vision 2030 plan, which aims to harness the Kingdom's vast cultural, tourism, and economic potential.

The AlUla region is home to an estimated 45,000 people, with a median age of 25.

The creation of Arts AlUla within the Royal Commission for AlUla (RCU) marked a commitment to the artistic creation. AlUla has long been an evolving and constant crossroads of cultural transfer. It was a commercial crossroads, and home to divers' civilizations that have carved, etched and inscribed their lives into the landscape. Arts AlUla's job is to seek to preserve this legacy: to merge the old with the new; the local with the international, keeping the arts at the heart of AlUla's spirit as a place of extraordinary natural and human heritage.

Arts AlUla is building a series of new initiatives, projects and exhibitions, alongside Afalula, together positioning the arts as key contributors to AlUla's character, the quality of life of its local community and the region's economic future. Arts AlUla aims to transfer the talents of the Saudi nation and the local AlUla community into meaningful and sustainable social and economic opportunities. This is an integral part of the "Journey through Time" plan, which brings together 15 different iconic destinations for culture, heritage and creativity across AlUla.

In this effervescent contemporary art scene, Afalula and Arts AlUla have co-founded the AlUla Artists and Designers Residency Programme. Created in 2020, over 50 artists have taken up residencies in AlUla so far and carried out research and artistic production. The AlUla Artist and Designer Residency programmes serves as a platform for regional and international artists to explore and experiment with their artistic pursuits against the backdrop of AlUla's awe-inspiring landscape, with its 200,000 years of human history.

After 5 years of on-site programmes in AlUla, which have fostered a dynamic dialogue and collaboration among artists and designers as well as with the scientific and local communities of AlUla, the strategy for the AlUla Artist Residency Programme is to find an echo chamber internationally, to promote the programme and its participating artists on relevant platforms outside Saudi Arabia, to cater to the cultural influence objective of both RCU and Afalula.

Following this approach, Afalula and RCU are organizing international exhibitions and activations of all forms to promote the destination and its programmes, and to showcase the outcomes of initiatives related to the arts and creative industries. These exhibitions are presented on carefully selected platforms such as biennales, art fairs, and/or festivals. These exhibitions serve as a form of soft promotion for the destination, highlighting the work of artists, designers, and other creatives who have participated in AlUla-related programmes over the past few years.

Vendors are invited to refer to previous comparable activations as benchmarks, including: AlUla Design at Salone del Mobile (Milan, 2024); Orbis Tertius (Art Basel Paris, 2024); Hall Hauss Design Days (Lafayette Anticipations, Paris Design Week 2024); NEUMA (Art Paris, 2025); and Future of Nostalgia (Tokyo Art Week, 2025).

## 2.1 Design

The selected provider will be responsible for the organisation, production, and operation of the design programme in Paris during Paris Design Week (September 2026), covering the following components:

### 2.1.1 Main exhibition – Lafayette Anticipations (Paris)

- The provider will deliver a new exhibition to be held at Lafayette Anticipations during Paris Design Week.
- The venue will be secured and provided by the Client and is therefore excluded from the scope; however, the provider will oversee all exhibition-related deliverables (production, coordination, installation, operation, contents creation, and dismantling).
- Dates: opening from 7 September 2026, for approximately one week (aligned with Paris Design Week schedule). Final date will be communicated during the bidding process, including set up and dismantling dates.
- Content: the exhibition will include:
  - All pieces developed during the AlUla Design Residency 2025/26 (list and specifications attached to the RFP). Inbound transport to Paris and pre-show storage will be arranged by the Client (out of scope). The designers and collectives are Altin Studio, Aseel Alamoudi, Paul Ledron, Ori Orisun Merhav, Studio Thus That. The provider shall coordinate and cover the return shipping of the pieces to the designers after the exhibition.(list will be provided during the bidding process)
  - a selection of works by Paul-Émile Marchesseau, who recently participated in a design residency at Villa Hagra (list will be provided during the bidding process),
  - A scenography that will occupy the 3 floors of Lafayette Anticipations
  - and additional new commissions / loans to be confirmed during the Q&A and bidding phase.
- The curatorial approach and statement are still in development. A preliminary list of participating designers and artworks will be shared with shortlisted bidders during the briefing meeting and may be subject to minor adjustments following contract award.

### 2.1.2 Satellite activation – Institut du Monde Arabe (IMA)

- The provider will support the organisation, production, and operation of a smaller activation at the Institut du Monde Arabe, in connection with the Arab Design Awards (or other relevant design initiatives).
- The venue if the Insitut du Monde Arabe in Paris, and will be provided in the framework of a partnership with institution.
- Date: 9 September 2026 (opening ceremony). Exact display dates will be confirmed during the Q&A process. Including set up and dismantling dates.
- The design piece(s) presented at IMA will be pre-produced and will originate from Madrasat Adeera Editions – Edition 2 (or other relevant initiatives). The production of the pieces themselves is not part of the provider's scope. Details of the pieces will be communicated later in the bidding process.

### 2.1.3 Retail / showcase corner – Galeries Lafayette (Champs-Élysées) - OPTIONAL

- The provider will support the set-up and operation of a small retail/showcase corner at Galeries Lafayette Champs-Élysées during Paris Design Week, to present and sell design objects linked to AIUla design initiatives (e.g., Arab Design Awards selections and/or other Saudi designers), in coordination with RCU / AFALULA.
- The venue is Galerie Lafayette in Champs Elysée, the dates will fit Paris Design Week dates and will be communicated during the Q&A.
- The content and exact format of this corner are still under development and will be clarified during the Q&A process. The production of the objects presented for sale is not part of the provider's scope. Details of the pieces will be communicated later in the bidding process.

Please note that this item is currently optional, and the Client may decide to cancel it depending on the available budget.

### 2.1.4 Public programmes

- The provider is also expected to produce and cover all related public programme activities as required (e.g., opening events, dinners, talks, and other programming), in coordination with the Client and partners related to stream described 1/2/3. The Client expect at least:
  - One opening event at Lafayette Anticipations (up to 1,000 guests).
  - One to two public programmes/activations per day during the Lafayette Anticipations exhibition (e.g., talks, conferences, performances, or other formats).
  - One dinner for organisers and participating designers/artists in Paris.
  - One talk at the Institut du Monde Arabe.

### 2.1.5 Additional – 1 international conference

- In addition, the provider will organise one international conference, following the model implemented in 2025 at Design Miami, including speaker management, travel, catering, and any costs related to partnership delivery. The Client will confirm the chosen platform during the Q&A process. This conference is not correlated to neither the exhibition at Anticipation / IMA / Corner at Galeries Lafayette.

### 2.1.6 PR & Comms

- The provider will subcontract a PR and Communications agency that will be chosen by the client. Considering the limited size of the project, the Client might choose one single press attaché for both items (design & arts) instead of a PR and communications agency. This will be communication during the bidding process.
- The provider will produce communications content required through a subcontractor selected by the Client.
- The provider will deliver the required communications materials for the programme (e.g., invitations, social media assets, videos, publications and other relevant content), in line with the Client's approvals process.

### 2.1.7 Partnership fees

- For this project, the provider will include and cover the relevant partnership fees for Lafayette Anticipations, the Institut du Monde Arabe, and Galeries Lafayette. The amounts (where not already fixed) will be communicated to bidders during the Q&A process.

## 2.2 Visual Arts

The selected provider will be responsible for the organisation, production, and operation of the visual arts activation in Paris in October 2026, delivered in partnership with Art Basel Paris, and structured as follows:

### 2.2.1 Main activation – Art Basel Paris (Grand Palais / off-site venues)

- The provider will deliver one large-scale artistic installation/exhibition in Paris during Art Basel Paris.
- Format: exhibition / installation bringing together existing artworks on loan + onsite production.
- Location: the activation will take place either within the fair itself (Grand Palais) or in one of the official related venues selected by Art Basel Paris as part of its public programme (Parcours).
- Opening period: the installation will be open strictly during the official dates of Art Basel Paris, from the press preview / first opening day through to the closing of the fair.

### 2.2.2 Content and artist (to be confirmed)

- The Client is currently finalising the artistic content (artist name and detailed list of works). This information will be shared with bidders during the tender process and through the Q&A sessions. Please note that this exhibition / installation is smaller than previous exhibition organized in the past by AFALULA (such as Orbis Tertius or Future of Nostalgia).
- The name of the artist will be communicated during the Q&A session, with formats envisioned yet subject to change:
  - two to four large-scale screen installations presenting existing video works,
  - a selection of additional works by the same artist (e.g., an existing photography series and/or other works),
  - and one commissioned onsite installation, subject to the venue allocated by Art Basel Paris.
  - [...] TBD

### 2.2.3 Partnership fee and related programming

- The provider will include and cover the partnership fee payable to Art Basel Paris. The amount will be communicated to bidders during the Q&A process.
- The provider is also expected to produce and cover all related activities as required (e.g., talks / conferences, public programme elements, dinners, opening events, and associated hospitality), in coordination with the Client and Art Basel Paris.

### 2.2.4 PR & Comms

- The provider will subcontract a PR and Communications agency that will be chosen by the client. Considering the limited size of the project, the Client might choose one single press attaché for both items (design & arts) instead of a PR and communications agency. This will be communication during the bidding process.

- The provider will produce communications content through a subcontractor appointed by the Client.
- The provider will deliver the required communications materials for the activation (e.g., invitations, social media assets, videos, publications and other relevant content), in line with the Client's approvals process.
- Please note that this item is the same as item 2.1.6 (same company or consultant)

#### 2.2.5 Additional - OPTIONAL

- The provider is expected to support the Client in delivering another art related outcome that is not directly linked to Art Basel Paris programme. This item consists in the organization of an online jury session for the 2026 AIUla Artist Residency Programme, to be held before the end of May 2026. Jury members and shortlisted artist profiles will be selected by the Client. The provider will prepare the required documentation and support materials, liaise with all stakeholders, and coordinate and facilitate the session (agenda, invitations, technical set-up, minutes and follow-up actions). Further details will be communicated during the Q&A sessions.

For both projects, the provider will report directly to the Client and be accountable to Simon Garcia, Director of Cultural Development at AFALULA. Day-to-day coordination will be led by Arnaud Morand, acting as Projects Director and Exhibitions Curator, in close collaboration with representatives from Arts AIUla, notably Ali Ghazzawi (Associate Curator, Design stream) and Candida Pestana (Director, AIUla Contemporary Art Museum – ACAM). The provider will also coordinate with important AFLAULA and RCU relevant departments, such as Communications department for relevant streams, under the supervision of the Bos. The provider will also be in contact with key partners, including Clément Délépine (Director of Lafayette Anticipations) and relevant team members, who will act as co-curators of the exhibition, as well as Galerie Lafayette team, IMA teams, Karim Crippa (Director, Art Basel Paris) and relevant team members.

### 3. Overview of the deliverables

AFALULA invites qualified vendors to submit proposals for the production and operational delivery of the two programmes described in Sections 2.1 (Design) and 2.2 (Visual Arts). The scope covers project management, production, technical coordination, installation, on-site operations, and post-event wrap-up, as detailed below.

#### 3.1 Design programme (Paris Design Week – September 2026)

The provider will deliver the Design programmes described in Section 2.1, including the main exhibition at Lafayette Anticipations, the satellite presentation at the Institut du Monde Arabe (IMA), the retail/showcase corner at Galeries Lafayette Champs-Élysées, and the related public programme (including one international conference).

##### 3.1.1 Deliverable A – Main exhibition at Lafayette Anticipations

Production, installation, operation, and dismantling of the exhibition at Lafayette Anticipations, including technical coordination, scenography fabrication, signage, AV and lighting requirements (as applicable), and day-to-day liaison with the venue's teams. The venue itself is provided by the Client and excluded from scope.

Key tasks include:

- Liaise with Lafayette Anticipations and appointed partners on technical constraints, access schedules, approvals, and H&S requirements.
- Source, brief, and contract technical companies and specialised vendors (scenography fabrication, AV, lighting, rigging, print/signage), as required.
- Oversee the production of scenography and signage, including prototyping, fabrication follow-up, and quality control.
- Coordinate the production of any new commissions included in the exhibition scope (as confirmed during the Q&A phase), and transportation / loan agreements of other pieces.
- Oversee installation, display systems, lighting, AV set-up, and all technical requirements; supervise dismantling and reinstatement.
- Coordinate shipping and transport under the agreed responsibility split: inbound transport to Paris and pre-show storage are arranged by the Client (out of scope); the provider coordinates and covers the return shipping of pieces to designers after the exhibition (packing, transport, customs documentation where applicable). And loan agreements.
- Ensure compliance with venue regulations, safety standards, and insurance requirements, and coordinate required documentation (risk assessments, method statements, certificates).
- Travel & accommodation of designers and other required stakeholders

##### 3.1.2 Deliverable B – Satellite activation at the Institut du Monde Arabe (IMA)

Support for the organisation, installation, operation, and dismantling of a small display integrated into an exhibition produced by the IMA team, in connection with the Arab Design Awards (or other relevant initiatives). The design piece(s) presented are pre-produced and their production is excluded from scope.

- Coordinate integration with IMA teams (display method, labels, lighting, security, access schedules).
- Produce and install any agreed supports, fixings, and signage, and manage dismantling and returns.

- Coordinate transport and handling to/from IMA (as agreed with the Client and partners).

### 3.1.3 Deliverable C – Retail / showcase corner at Galeries Lafayette Champs-Élysées

Set-up, operation, and dismantling of a dedicated retail/showcase corner during Paris Design Week, including fit-out, in-store graphics, logistics, compliance with venue constraints, and coordination with the Client's appointed partners. The objects presented for sale are pre-produced and their production is excluded from scope.

- Coordinate with Galeries Lafayette on layout, merchandising rules, security, opening hours, and access.
- Oversee fit-out and in-store graphics production/installation (within brand guidelines and approvals).
- Organise transport, receipt, inventory check, and secure storage as required for displayed items.
- Support operational handover to retail teams (labels, pricing display, product list, basic care/handling notes).

### 3.1.4 Deliverable D – Public programme and conference

Delivery of one international conference, following the model implemented in 2025 at Design Miami, and production support for related events as required (openings, dinners, talks, and other public programme elements), in coordination with the Client and partners.

- Speaker and participants management (invitations, confirmations, briefing notes, schedules, contracts where applicable, fees when applicables).
- Travel and accommodation coordination for speakers, and on-site hospitality (catering, receptions) as required.
- Technical production (stage set-up, sound, projection, recording/streaming if required, F&B if required) and run-of-show management.
- Coordination with partnership counterparts appointed by the Client, including alignment on branding and deliverables.

### 3.1.5 Deliverable E – PR & communications support

The provider will coordinate with the PR and communications agency and content subcontractors appointed by the Client, and will produce the operational inputs required for communications deliverables.

- Provide planning inputs, approvals workflow support, and consolidated credits/captions.
- Coordinate on-site access for photographers/videographers and manage shooting schedules with venues.
- Deliver required operational assets (floor plans, key dates, technical details, contact lists) and ensure timely validations.

### 3.1.6 Partnership fees

The provider will include and cover the partnership fees linked to Lafayette Anticipations, the Institut du Monde Arabe, and Galeries Lafayette. Amounts (where not already fixed) will be communicated during the Q&A process.

### **3.2 Visual arts activation (Art Basel Paris – October 2026)**

The provider will deliver the Art Basel Paris activation described in Section 2.2, including production and operations for the installation/exhibition, coordination with Art Basel Paris and the selected venue(s), and delivery of any related programming (talks, hospitality, opening events), as required.

#### 3.2.1 Deliverable F – Art Basel Paris installation/exhibition

Production, installation, operation, and dismantling of one large-scale installation/exhibition during Art Basel Paris (within the fair and/or an official off-site venue), combining existing works on loan with onsite production. The activation will be open strictly during the fair's official dates (press preview to closing).

- Liaise with Art Basel Paris and the allocated venue(s) on technical constraints, access schedules, approvals, and operational protocols.
- Source and contract technical companies and specialised vendors (fabrication, AV, lighting, rigging, print/signage) as required for the proposed installation.
- Oversee the production of scenography, display systems, and technical elements, including any commissioned onsite components, in accordance with venue constraints.
- Coordinate shipping, transport, and handling of artworks (loaned works and any newly produced elements), including packing standards, condition reporting, and return logistics.
- Ensure appropriate insurance coverage for artworks and production activities, and compliance with safety and venue regulations.
- Plan and manage installation and dismantling teams, on-site supervision, daily checks, and troubleshooting during the opening period.
- Travel & accommodation of artists and artists fees

#### 3.2.2 Deliverable G – Partnership fee and related programming

The provider will include and cover the partnership fee payable to Art Basel Paris (amount communicated during the Q&A process) and will produce any related public programme elements as required, in coordination with the Client and Art Basel Paris.

- Coordinate with Art Basel Paris on partnership deliverables, technical requirements, brand guidelines, and approvals.
- Produce and operate related moments as required (e.g., talks, dinners, opening events, associated hospitality), including supplier coordination, run-of-show, and guest logistics where applicable.

#### 3.2.3 Deliverable H – PR & communications support

As for the design programme, the provider will coordinate with the PR and communications agency and content subcontractors appointed by the Client, and will deliver the operational inputs and assets needed for communications purposes.

- Collect and share verified credits, captions, and technical information for artworks and venues.
- Coordinate on-site access, shooting schedules, and approvals with venues and partners.
- Provide operational support for invitations and guest flows where required for openings and public programme moments.

### 3.2.4 Deliverable I - Additional

The provider will support the Client in organising and delivering the online jury session for the selection of the 2027 ALULA Artist Residency Programme, to be held before the end of May 2026. Jury members and shortlisted artist profiles will be selected by the Client.

The provider's scope includes:

- Planning and scheduling: confirm date(s), agenda, run-of-show, and key milestones.
- Jury materials: compile/format the jury pack (profiles, portfolios, supporting documents), ensure version control, and circulate securely to be developed with the client and validated by the client ahead of session
- Stakeholder coordination: liaise with jury members and Client representatives (invitations, reminders, practical information, votes).
- Online delivery: manage the technical set-up, moderate/facilitate the session (timekeeping, screen-sharing, Q&A flow).
- Documentation: produce minutes and a short decision/action summary for Jury validation, and coordinate follow-up actions.
- Fees of Jury (to be communicated during the Q&A sessions)
- Etc.

Further details will be communicated during the Q&A sessions.

### **3.3 Cross-cutting requirements (both programmes)**

The provider shall meet the following cross-cutting requirements for both programmes:

- Provide an organisational chart for the dedicated project team (roles, seniority, short bios, and CVs). Project management must be led by a senior professional with at least 10 years of experience delivering comparable arts and culture projects.
- Establish and manage the overall project plan (timeline, milestones, dependencies, deliverables), including an integrated installation/dismantling schedule per venue.
- Set up reporting routines with the Client (weekly check-ins, action tracker, decision log) and issue regular written progress updates.
- Track budgets and costs, maintain cost control, and provide regular financial reporting (incl. committed vs. spent, forecast to complete, and variance notes).
- Coordinate all external suppliers and technical partners (briefing, procurement, contracts, production monitoring, acceptance checks).
- Coordinate travel and logistics for designers/artists/speakers as required (tickets, accommodation, local transport, per diems where applicable), in line with Client policies.
- Ensure compliance with venue regulations, safety standards, and insurance requirements; prepare and submit all required documentation (risk assessments, method statements, certificates, permits where applicable).

- Arrange insurance coverage for artworks and production activities as required by the venues and the Client, and manage incident reporting procedures.
- Oversee packing, handling, transport, installation, de-installation, and return logistics for exhibited works (as per the agreed responsibility split in Section 2).
- Deliver a post-event wrap-up package, including final documentation (professional photo/video where applicable and available), final credits, a consolidated supplier pack (as-built / tech specs), and a concise post-project report (key figures where applicable, lessons learned, recommendations).

The provider shall ensure compliance with venue regulations, safety standards, and insurance requirements; coordinate all suppliers and technical partners; and deliver a final wrap-up package including professional photo/video documentation, credits, and a concise post-project report (key figures where applicable, lessons learned, and recommendations).

#### 4. Timeline Overview

| Program                            | Date                      | Details   |
|------------------------------------|---------------------------|-----------|
| <b>1. Preparation and Logistic</b> | From awarding to August   | See above |
| <b>2. Deployment</b>               | From September to October | See above |
| <b>3. Amplification</b>            | From August to November   | See above |

## 5. Vendor Role and Responsibility

The provider must have prior experience delivering comparable projects in Saudi Arabia and in France (or internationally, with equivalent institutional and technical constraints).

The vendor is invited to undertake this project as a commercial operation. The vendor might not be credited in the project as an organizer or partner. The programme will only feature the client and other potential partners chosen by the client. As much as possible the provider will be featured as “producer”, in accordance with RCU rules and regulations.

The vendor is invited to respond to this RFP by developing a proposal that includes a detailed logistic plan for this programmes and associated budgets.

The provider may not contact any artist / designer nor partners during the tender phase without the Client’s prior approval. The provider may not request any exclusivity from freelancers or subcontractors; freelancers and subcontractors remain free to bid with multiple bidders.

The Client can ask the vendor to work with specific experts / freelance / subcontractor, should it be for production, artists liaison, curatorial support, project management or any other relevant expertise needed as part of the Project.

## Annex 1. Vendor Application Dossier Requirements

The vendor will be selected based on their specialization in the fields of visual art/ creative industries, cultural engineering, and cultural programming, and their demonstrated experience in arts & culture project management, according to the technical excellence of their proposition and financial accuracy of their commercial offer.

Interested vendors should submit their proposals electronically to [simon.garcia@afalula.com](mailto:simon.garcia@afalula.com) [arnaud.morand@afalula.com](mailto:arnaud.morand@afalula.com) cc Ali [a.alghazzawi@rcu.gov.sa](mailto:a.alghazzawi@rcu.gov.sa) / [audrey.chazal@external.afalula.com](mailto:audrey.chazal@external.afalula.com) / [emily.marant@external.afalula.com](mailto:emily.marant@external.afalula.com) no later than April 13th, 2026 at 10.00 pm CET. Late submissions will not be considered.

The proposals will be appraised by a group of experts within the client team

The files submitted by applicants must include:

### 1. Administrative Documents:

- Kbis of the company
- Company name and Kbis of subcontractors and co-contractors, if any.

### 2. Commitment Form / Act of Engagement Form:

- Document filled and signed

### 3. The financial offer

### 4. The technical offer (PPT or PDF) comprising:

- Dossier in the form of PPT presentation or PDF
- Company presentation and valorization
- Project team / organizational chart with defined roles & responsibilities
- Relevant projects & examples
- Methodology
- Detailed proposition

## **Annex 2. Process and Criteria of Application Assessment**

- **Process:**

Several 1-hour Q&A sessions will be held during the bidding process, (day and time TBC), during which AFALULA/RCU will be available to answer any questions applicants may have about the project.

A panel of experts from Afalula and RCU will review the proposals. Afalula reserves the right to reject any and all proposals, to waive any and all formalities outlined in the RFP and in the selection process and generally to make the award that in its judgment, will best meet the objectives stated in this RFP

- Release Date: April 15th, 2026
- Feedback on interest / participation to the competition to be received before April 22nd, 2026
- Explanation / Q&A meeting: April 27th, 2026 time TBD
- Enquiries Cut-off Date: April 30th, 2026
- Response Deadline: May 11th 2026

All dates in the RFP are subject to change at the discretion of Afalula and notice of any changes will be provided to all respondents.

Submission of the complete offer is due on May 11<sup>th</sup>, 2026, by electronic transmission of the files in PPT or PDF format.

After verification of the conformity of the administrative, technical, and financial files, compliant bids will be evaluated in accordance with Afalula's internal procedures.

- Afalula reserves the right to ask candidates for additional explanatory and/or supporting documents.
- Afalula reserves the right to organize an oral discussion and questioning session with shortlisted candidates prior to the final selection of the winner.

All applicant vendors will be made aware of the final selection for this development phase and will be invited to stay in the loop as their profiles may be relevant for the following deployment phase.

• **Criteria:**

All applications will be reviewed through the lens of the following criteria:

| CRITERIA  | PERCENTAGE (%) |
|---|----------------|
| <b>1. TECHNICAL OFFER</b>   | <b>60%</b>     |
| <b>1.1. RELEVANCE OF COMPANY, PROJECT UNDERSTANDING, &amp; RELEVANT SIMILAR REFERANCES</b>          | <b>15%</b>     |
| <b>1.2. TEAM MEMBERS / EXPERT'S CVs</b>   | <b>10%</b>     |
| <b>1.3. DELIVERABLES</b>  | <b>35%</b>     |
| <ul style="list-style-type: none"> <li>• Technical proposal (production &amp; logistic )</li> </ul> | 25%            |
| <ul style="list-style-type: none"> <li>• Project Management Skills and methodology</li> </ul>       | 10%            |
| <b>2 FINANCIAL OFFER</b>  | <b>40%</b>     |

### Annex 3. Commitment Form

#### LETTER OF COMMITMENT

(To be signed and included in the application file)

I, the undersigned, .....

(first name, last name, and position within the company), acting in the name and on behalf of

.....

(company name and legal form, address), hereby confirm that I have reviewed the consultation documents for the project entitled "Capacity-Building Support Mission" for the Development Department of AFALULA.

By signing this document, our company commits, if selected by AFALULA, to carrying out the required services in full compliance with the terms of the consultation guidelines and in accordance with the conditions set out in our application, composed of:

- The administrative file
- The technical proposal
- The financial offer

Done in ..... on .....

(Signature of the legal representative of the applicant)

| Artist Name: Paul Ledron     |           | Artwork         | pickup location :KSA ALULA  |      |             |                                |                        |
|------------------------------|-----------|-----------------|-----------------------------|------|-------------|--------------------------------|------------------------|
| #                            | CRATE NO. | Crate Dimension |                             |      | Weight (kg) | Description                    | Surface area m squared |
|                              |           | L               | W                           | H    |             |                                |                        |
| 1                            | Crate 1   | 73              | 217                         | 73   | 100         | Lamp Shade                     | 7.40                   |
| 2                            | Crate 2   | 62              | 162                         | 62   | 100         | Incense Tower & Incense Drawer | 4.79                   |
| 3                            | Crate 3   | 108             | 69                          | 58   | 100         | Bench 1                        | 3.54                   |
| 4                            | Crate 4   | 108             | 69                          | 58   | 100         | Bench 2                        | 3.54                   |
| 5                            | Crate 5   | 250             | 89                          | 95   | 170         | Daybed                         | 10.89                  |
|                              |           |                 |                             |      |             |                                |                        |
| Artist Name: Ori Orisun      |           | Artwork         | pickup location : KSA ALULA |      |             |                                |                        |
| #                            | CRATE NO. | Crate Dimension |                             |      | Weight (kg) | Description                    | Surface area m squared |
|                              |           | L               | W                           | H    |             |                                |                        |
| 6                            | Crate 1   | 258             | 174                         | 100  | 202         | Palm Glow                      | 17.62                  |
| 7                            | Crate 2   | 190             | 90                          | 78   | 98          | Palm Glow                      | 7.79                   |
| 8                            | Crate 3   | 95              | 90                          | 87   | 130         | Palm Rock                      | 4.93                   |
| 9                            | Crate 4   | 162             | 82                          | 27   | 45          | Palm Throne                    | 3.97                   |
| 10                           | Crate 5   | 145             | 170                         | 34   | 86          | Palm Rock                      | 7.07                   |
|                              |           |                 |                             |      |             |                                |                        |
| Artist Name: Altin Studio    |           | Artwork         | pickup location : KSA ALULA |      |             |                                |                        |
| #                            | CRATE NO. | Crate Dimension |                             |      | Weight (kg) | Description                    | Surface area m squared |
|                              |           | L               | W                           | H    |             |                                |                        |
| 11                           | Crate 1   | 120             | 80                          | 100  | 250         | Wadi Wood Pieces               | 5.92                   |
| 12                           | Crate 2   | 120             | 80                          | 100  | 250         | Wadi Wood Pieces               | 5.92                   |
| 13                           | Crate 3   | 120             | 80                          | 100  | 250         | Wadi Wood Pieces               | 5.92                   |
| 14                           | Crate 4   | 120             | 80                          | 115  | 250         | Wadi Wood Pieces               | 6.52                   |
| 15                           | Crate 5   | 120             | 80                          | 115  | 250         | Wadi Wood Pieces               | 6.52                   |
| 16                           | Crate 6   | 157             | 58                          | 123  | 250         | Wadi Wood Pieces               | 7.11                   |
| 17                           | Crate 7   | 250             | 101                         | 66   | 200         | Metal Sheets                   | 9.68                   |
| 18                           | Crate 8   | 290             | 81                          | 44   | 200         | Metal Sheets                   | 7.96                   |
| 19                           | Crate 9   | 274             | 71                          | 46   | 200         | Metal Sheets                   | 7.06                   |
| 20                           | Crate 10  | 307             | 91                          | 56   | 200         | Waha Wood Pieces               | 10.05                  |
| 21                           | Crate 11  | 144             | 129                         | 127  | 200         | Waha Wood Pieces               | 10.65                  |
| 22                           | Crate 12  | 163.5           | 121.5                       | 71.5 | 200         | Yusur Wood Pieces              | 8.05                   |
|                              |           |                 |                             |      |             |                                |                        |
| Artist Name: Aseel Alamoudi  |           | Artwork         | pickup location :KSA ALULA  |      |             |                                |                        |
| #                            | CRATE NO. | Crate Dimension |                             |      | Weight (kg) | Description                    | Surface area m squared |
|                              |           | L               | W                           | H    |             |                                |                        |
| 23                           | Crate 1   | 220             | 163                         | 66   | 455         | Bench                          | 12.23                  |
| 24                           | Crate 2   | 88              | 62                          | 63   | 148         | Stool                          | 2.98                   |
|                              |           |                 |                             |      |             |                                |                        |
| Artist Name: Studio ThusThat |           | Artwork         | pickup location : KSA ALULA |      |             |                                |                        |
| #                            | CRATE NO. | Crate Dimension |                             |      | Weight (kg) | Description                    | Surface area m squared |
|                              |           | L               | W                           | H    |             |                                |                        |
| 25                           | Crate 1   | 180             | 85                          | 65   | 200         | Segment 1                      | 6.51                   |
| 26                           | Crate 2   | 180             | 85                          | 65   | 200         | Segment 2                      | 6.51                   |
| 27                           | Crate 3   | 180             | 85                          | 65   | 200         | Segment 3                      | 6.51                   |
| 28                           | Crate 4   | 180             | 85                          | 65   | 200         | Segment 4                      | 6.51                   |
| 29                           | Crate 5   | 180             | 85                          | 65   | 200         | Segment 5                      | 6.51                   |
| 30                           | Crate 6   | 180             | 85                          | 65   | 200         | Segment 6                      | 6.51                   |
| 31                           | Pallet 1  | 180             | 70                          | 50   | 1,000       | Rock Pallet 1                  | 5.02                   |
| 32                           | Pallet 2  | 180             | 70                          | 50   | 600         | Rock Pallet 2                  | 5.02                   |
| 33                           | Pallet 3  | 180             | 70                          | 50   | 800         | Rock Pallet 3                  | 5.02                   |
|                              |           |                 |                             |      |             |                                | 232.21                 |
|                              |           |                 |                             |      | 8,034       | <b>232.21 m squared</b>        |                        |



## Altin Studio

Altin Studio, founded by Yasmine Sfar and Mehdi Kebaier, works to reimagine Tunisian craft as a living, contemporary practice. With backgrounds in interior architecture and civil engineering, they merge material sensitivity with technical precision. Working from a family-run atelier in Tunisia, they collaborate closely with local artisans to produce refined, site-rooted works. In 2023, they launched *Orbite*, their debut collection, which explores the intersection of tradition and experimentation through four primary materials : metal, rush, wood, and clay. Altin Studio's approach reflects a deep respect for ancestral knowledge and a confidence in the enduring potential of craft as a vector for sustainable production inspired by ancient traditions.

### Artworks displayed in the exhibition

- Wadi Bookshelf
- Waha Canopy
- Yusr Table



## Aseel Othman Alamoudi

Aseel Othman Alamoudi is an architect and designer based in Jeddah. Her visual language, developed during graduate studies at SCI-Arc, moves across scales and formats, from sculptural objects to large spatial interventions. She explores the ontology of form and material in shifting contexts, using architecture as a tool for inquiry. Her projects include *Flattened Spaces* at POUCH in Paris (2024), *Untitled Object: The Table at YSA in Diriyah* (2023), and *Urban Object for Noor Riyadh* (2022). She also took part in NEOM's *Zero Gravity Urbanism Residency in Venice* (2023)

### Artworks displayed in the exhibition

- Bench & Stool
- 3D model



## Ori Orisun Merhav

Ori Orisun Merhav is a designer and material researcher based in Brussels. A graduate of Design Academy Eindhoven, she explores the intersections of craft, ecology and technology. She is the founder of Made by Insects, an ongoing study of lac, a natural polymer secreted by insects. In 2023, she developed the first 3D-printed shellac objects in collaboration with Reflexlab and Ginger Additive. Her studio creates sculptural installations, research artifacts and collectible pieces. In 2024, she was commissioned by the Centre Pompidou and appointed associate researcher at the Bio-Polymer Lab at Avans.

### Artworks displayed in the exhibition

- Palm Glow
- Palm Rock



## Paul Moustapha Ledron

Paul Moustapha Ledron is a furniture designer whose work grows from West African imaginaries and recasts them in a contemporary design language. Born in Mali and raised in Côte d'Ivoire, he studied Industrial Design in London and completed a master's in Branding in Sofia before returning to Abidjan to establish his practice. His influences span Malian, Martiniquais, and German lineages, informing a craft-driven approach that balances cultural memory with forward vision. In 2023 he exhibited during Paris Design Week with Jean-Servais Somian and won Abidjan's Young Creator Prize at the Forum des Métiers du Luxe. In 2024 he was selected for the Dakar Biennale's revived design section and named among the Forbes Afrique's Top 30 Under 30.

### Artworks displayed in the exhibition

- Lamp
- Incense Tower & Benches
- Daybed



## Studio ThusThat

Studio ThusThat, founded by Kevin Rouff and Paco Böckelmann, explores the unseen narratives of material production. Drawing from academic foundations in design, engineering, and science at institutions such as Stanford, Twente, Imperial College and the Royal College of Art, they work at the convergence of design, research and material storytelling. Their practice engages deeply with industrial byproducts, particularly from mining and metallurgy, to propose new ways of seeing value in waste. Through objects, interiors and installations, they investigate material legacies while speculating on alternative futures. Their work has been exhibited internationally and is held in the permanent collections of the London Design Museum, Design Museum Gent and FRAC Dunkerque.

### Artworks displayed in the exhibition

- Bench

# EXHIBITION\_Artworks\_Altin Studio



### Wadi Bookshelf

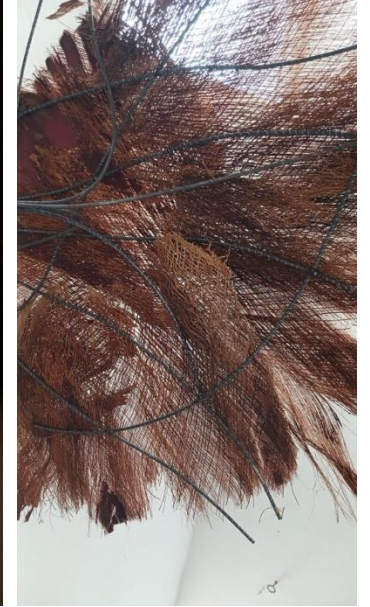
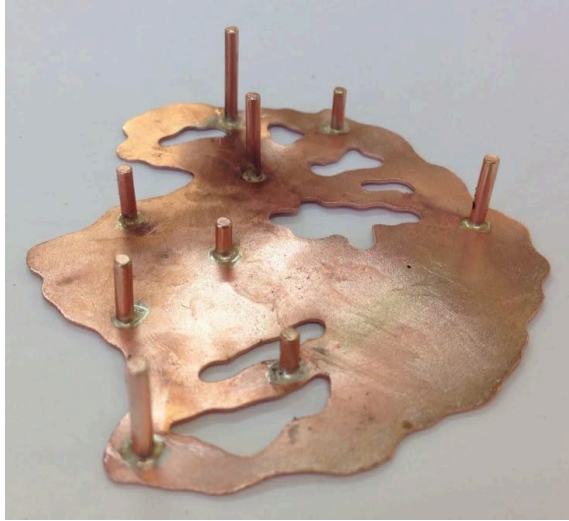

### Waha Canopy



### Yusr Table

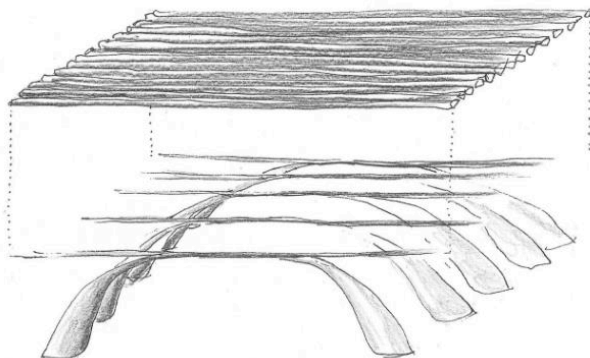

SECOND LAYER  
TABLE TOP MADE OF  
LINEAR PALM RODS.  
WOVEN WITH COPPER WIRE

FIRST LAYER  
TABLE LEG SUPPORTING TOP  
NATURAL PALM FROND WITH  
BASE CURVATURE



## Product statements

Altin Studio's body of work, developed during the residency, unfolds as a triptych—Wadi, Waha, and Yusr—each piece tracing a material and spatial dialogue with the AlUla oasis. Anchored in collaborative research with local craftspeople and an intensive study of the palm as both ecological resource and cultural archive, the studio's approach renders the landscape not as backdrop, but as co-author.

Wadi, a monumental structure composed of thirty palmwood volumes, engages with the typology of the library as a space of sedimented knowledge. These tactile forms—stacked, carved, and charred—recall geological strata, mudbrick ruins, and Nabatean script, embedded within a rusted steel framework that evokes the iron hues of AlUla's cliffs.

Waha, by contrast, is a suspended canopy of braided palm fronds and metal rods, light and tensile, channeling the oasis' capacity for softness and shelter.

Finally, Yusr distills this research into a modest yet rigorous table form: upright palm bundles cinched with copper, invoking both architectural logic and intimate scale. Across the three works, Altin Studio positions the palm not simply as a material but as a transmitter of time, labor, and place—an agent in the design of collective memory from Tunisia to AlUla.

# EXHIBITION\_Artworks\_Aseel Othman Alamoudi



ALULA  
DESIGN  
AWARD  
جائزة  
العلا  
للتصميم

ARTS  
ALULA  
فنون  
العلا

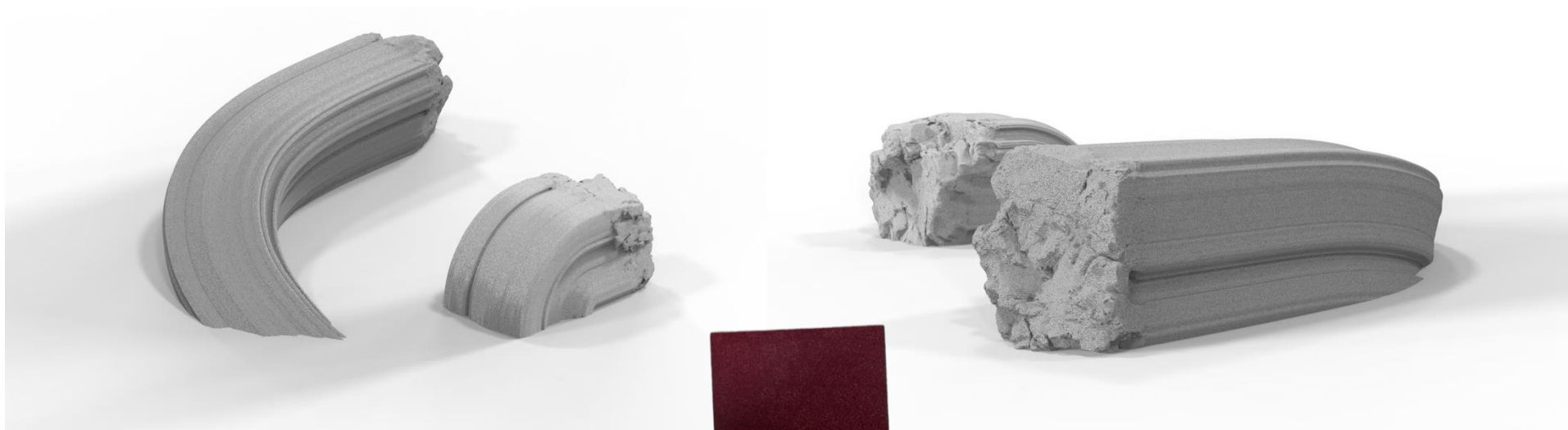

Bench & Stool

# EXHIBITION\_Artworks\_Aseel Othman Alamoudi



ALULA  
DESIGN  
AWARD  
جائزة  
العلا  
للتصميم

ARTS  
ALULA  
فنون  
العلا

## Product statements

Aseel Alamoudi's research during the residency foregrounds the performative potential of urban design when embedded in geological imagination. Her playful urban furniture intervention reconsiders the bench not just as a utilitarian object, but as an active element within landscape and daily life—becoming a marker of time, erosion, and encounter. Informed by the shifting tectonics of AlUla's terrain, the bench's form emerges through an iterative modeling process: fractured, layered, and cast in fiber-reinforced polymer to resemble the sedimentary seams of the desert cliffs. The structure invites users to sit, climb, or recline across a series of extrusions that are at once playful and meditative. Designed to weather and patinate with sun and sand, the bench evolves with its environment—its surface absorbing the passage of time. This intervention is part of a wider design scheme to reimagine play spaces in AlUla, positioning urban furniture as a site of interaction, memory, and transformation.

# EXHIBITION\_Artworks\_Ori Orisun Merhav



Palm Glow

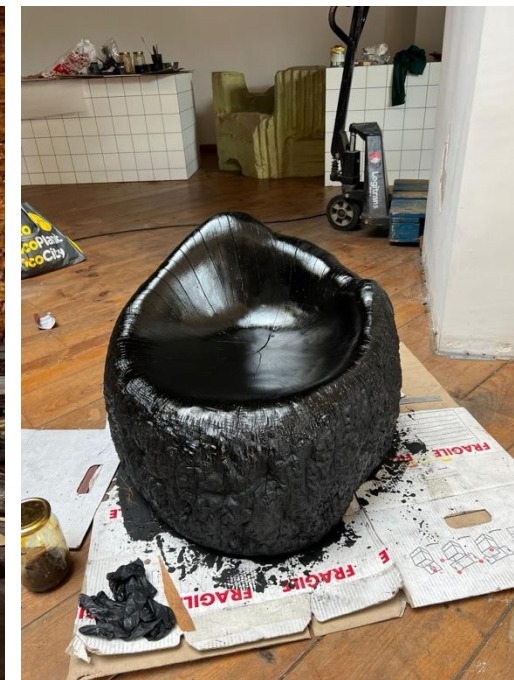

Palm Rock

# EXHIBITION\_Artworks\_Ori Orisun Merhav



ALULA  
DESIGN  
AWARD  
جائزة  
العلا  
للتصميم

ARTS  
ALULA  
فنون  
العلا

## Product statements

During the residency, Ori Orisun Merhav expanded her ongoing inquiry into the palm as a multispecies material system, proposing a design practice in conversation with ancestral technology, ecological tactility, and craft ritual. Her lighting sculptures begin with palm sheaths—once discarded agricultural remnants—transformed through a process of pressing, shellac-coating, and thermal curing. The resulting forms are biomorphic, translucent, and resinous, radiating a warm amber light that feels both ancient and futuristic. Parallel to this, Merhav’s seating designs are hand-shaped from oil-treated palm stalks, their curvatures retained and accentuated to honor the natural movement of the plant. Dried date pigments extracted from the pits become part of a material language rooted in sensorial depth and cultural trace. Rather than treating the palm as a static resource, Merhav listens to its micro-histories—its frictions, scents, and curvatures—rendering her objects as tools for re-imagining kinship with the vegetal world. In this residency, she stages design as a form of embodied, intimate research—an interface between the ritual and the speculative.

# EXHIBITION\_Artworks\_Paul Moustapha Ledron



Daybed



Incense Tower & Benches



# EXHIBITION\_Artworks\_Paul Moustapha Ledron



جائزة ALULA  
العلا DESIGN  
للتصميم AWARD

فنون ARTS  
العلا ALULA

## Product statements

Paul Moustapha Ledron's residency unfolds as a poetic dialogue with the temporal, cultural, and ecological rhythms of the AlUla oasis. Rooted in sensory research and close observation, his practice centers on slowness, where design becomes an invitation to dwell, breathe, and attune. Through a constellation of objects designed and manufactured in Saudi Arabia from a mix of black-dyed meranti and sandiyan wood, Ledron builds a spatial language of pause: a vertical lamp crowned with handmade palm paper tiles filters light like a sun-dappled canopy; a daybed upholstered in hand-quilted cyanotype fabric transforms sun-exposed textile fragments into a cushioned surface for semi-upright repose; and a triangular incense altar composed of freestanding benches, a perforated chimney, and a ceramic drawer releases scent in slow intervals, its brass inlays tracing ephemeral paths.

Across these works, materials including the meranti–sandiyan mix, palm paper, cyanotype textiles, brass, and ceramic become metaphors for pause, passage, and attentive presence. Together, they reject spectacle in favor of subtlety, offering a meditative counterpoint to the accelerated pace of contemporary design. Ledron's residency reveals the oasis not only as a landscape, but as a temporal practice, a rhythm of rest, memory, and attunement.

# EXHIBITION\_Artworks\_Studio ThusThat



ALULA  
DESIGN  
AWARD  
جائزة  
العلا  
للتصميم

ARTS  
ALULA  
فنون  
العلا

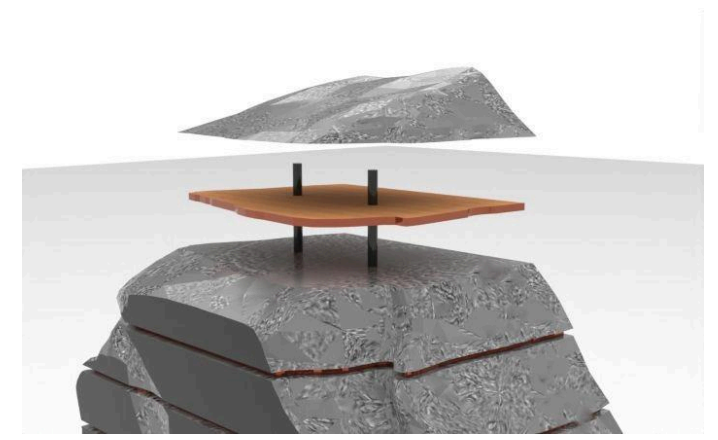
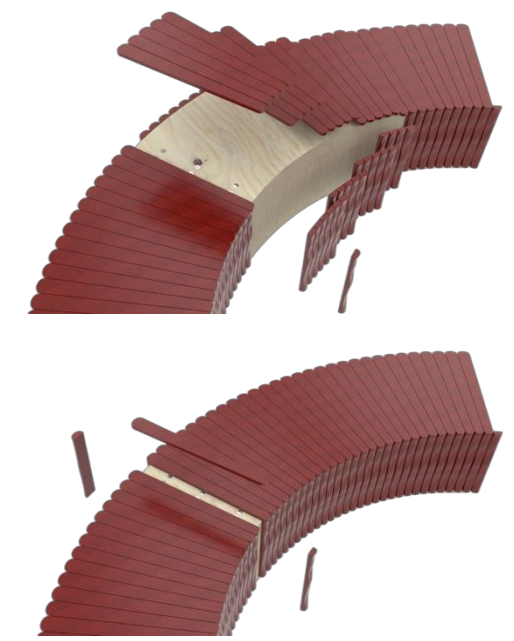

# EXHIBITION\_Artworks\_Studio ThusThat



ALULA  
DESIGN  
AWARD  
جائزة  
العلا  
للتصميم

ARTS  
ALULA  
فنون  
العلا

## Product statements

Studio ThusThat's residency is framed by a deep interrogation of material afterlives—specifically, the dialogue between geologic formation and industrial byproduct. Their research in the volcanic region of AlUla, alongside the broader context of Saudi Arabia's mineral extraction industries, led to an unlikely material pairing: basalt, a naturally occurring igneous rock, and slag, a metallurgical waste product. The resulting seating piece draws on cairns, ancient stacked stone markers, as both formal and conceptual anchors, reimagined here as contemporary monuments to transformation and residue. Slag is cast and manipulated to mimic lava, producing surfaces that shimmer with metallic unpredictability, while basalt is carved into precise, weighted geometries. The tension between these materials, between what is mined and what is discarded, becomes the narrative core of the work. For Studio ThusThat, the design process is not only technical but forensic: a means of excavating histories embedded in matter. Their residency outcomes challenge extractive logic by staging new material imaginaries, proposing design as both critique and proposition—an inquiry into the possibilities of planetary futures.

# THANK YOU

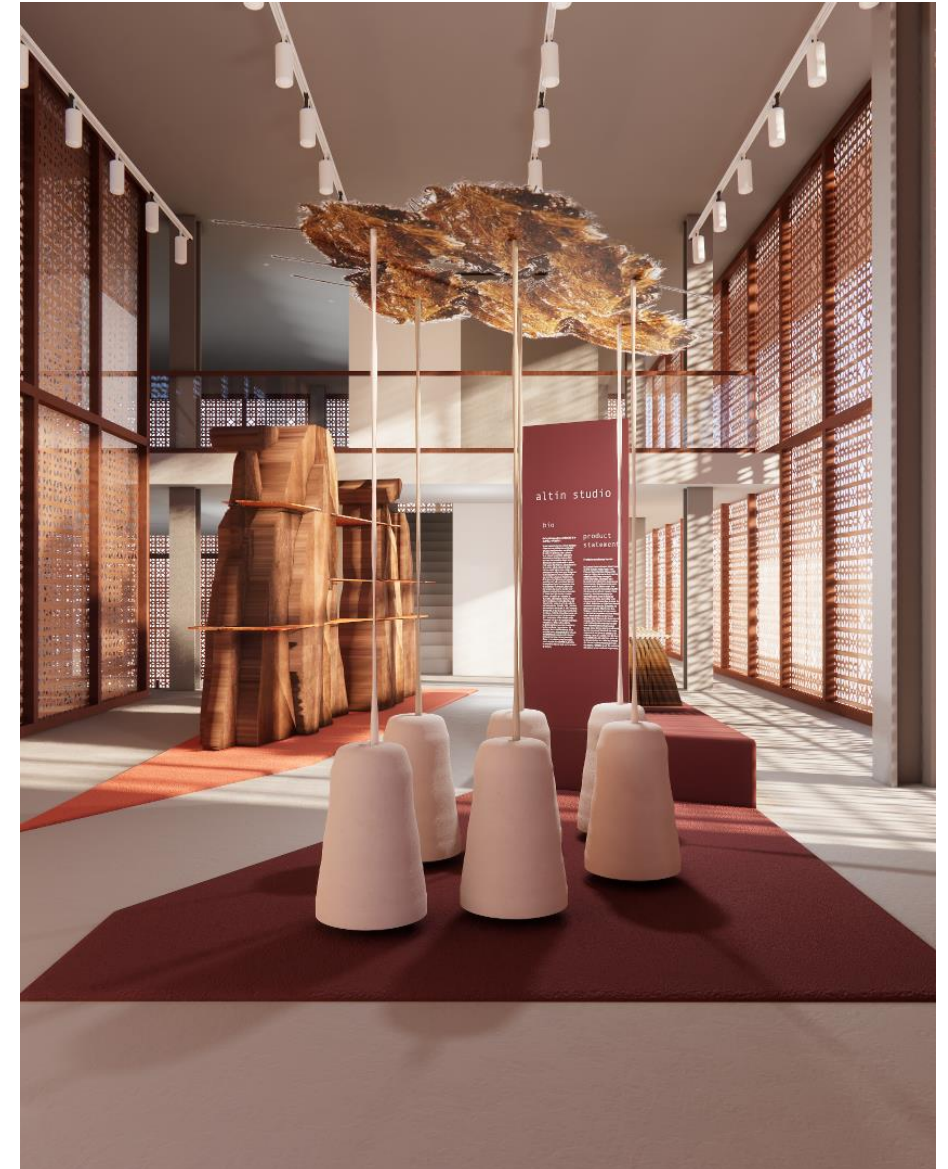



# Soundsystem

Dimensions according to plans to be  
verified according to production  
**H 300cm x L 240cm x I 190cm**

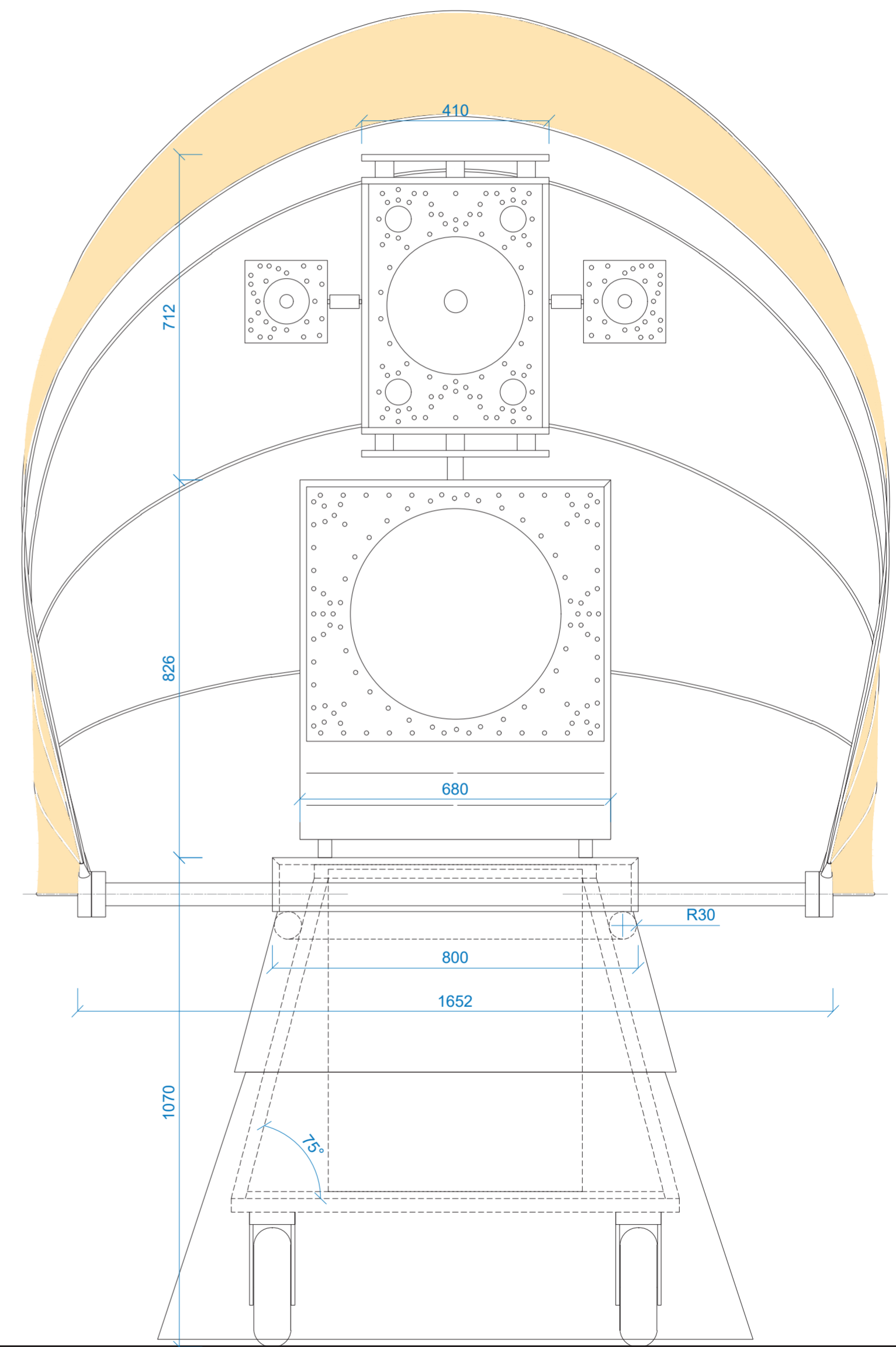
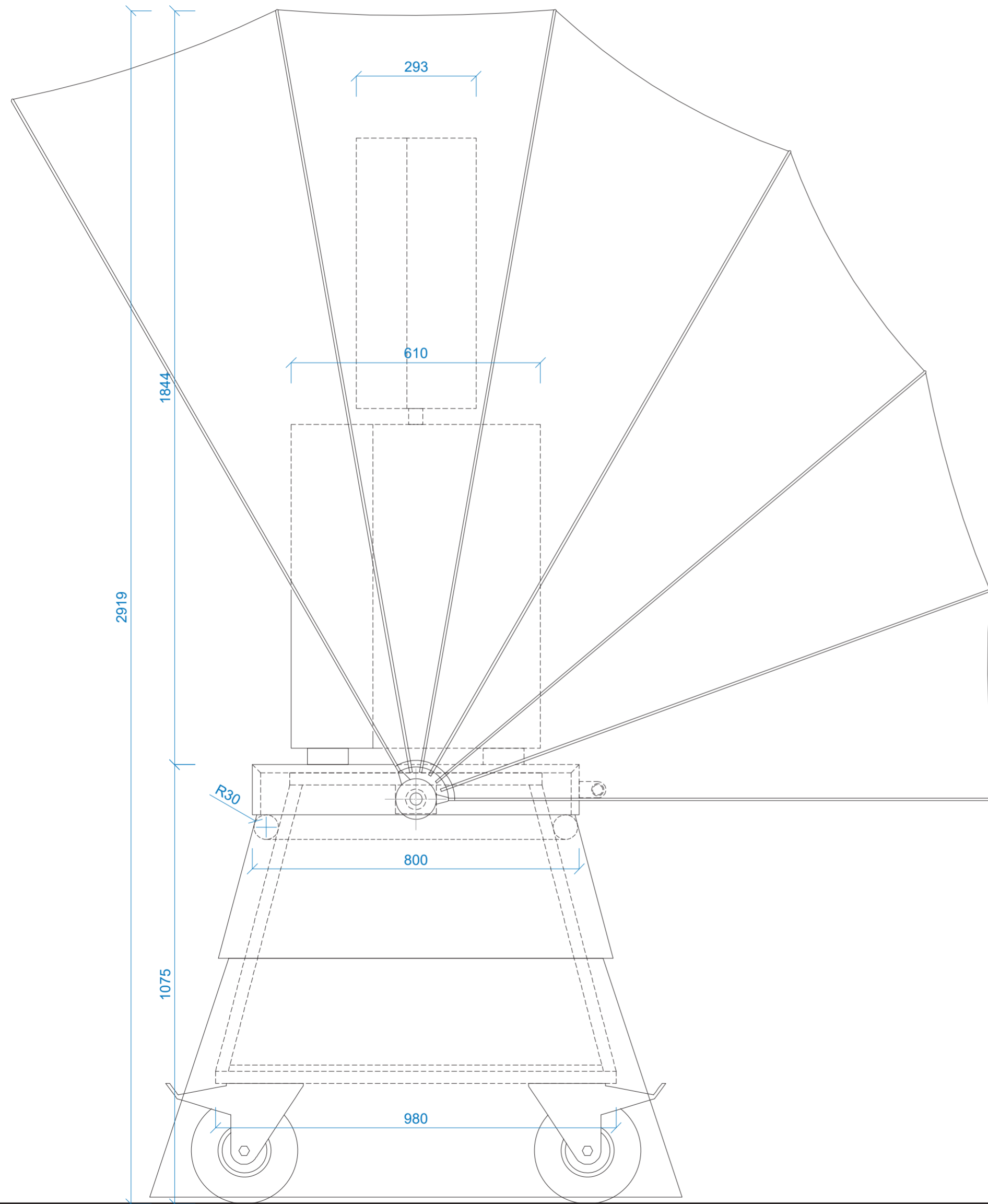





Dimensions amplifier / battery  
**H 80,5cm x L 60cm x I 55cm**

Dimensions top speaker without side speakers  
**H 68cm x L 41cm x I 30cm**

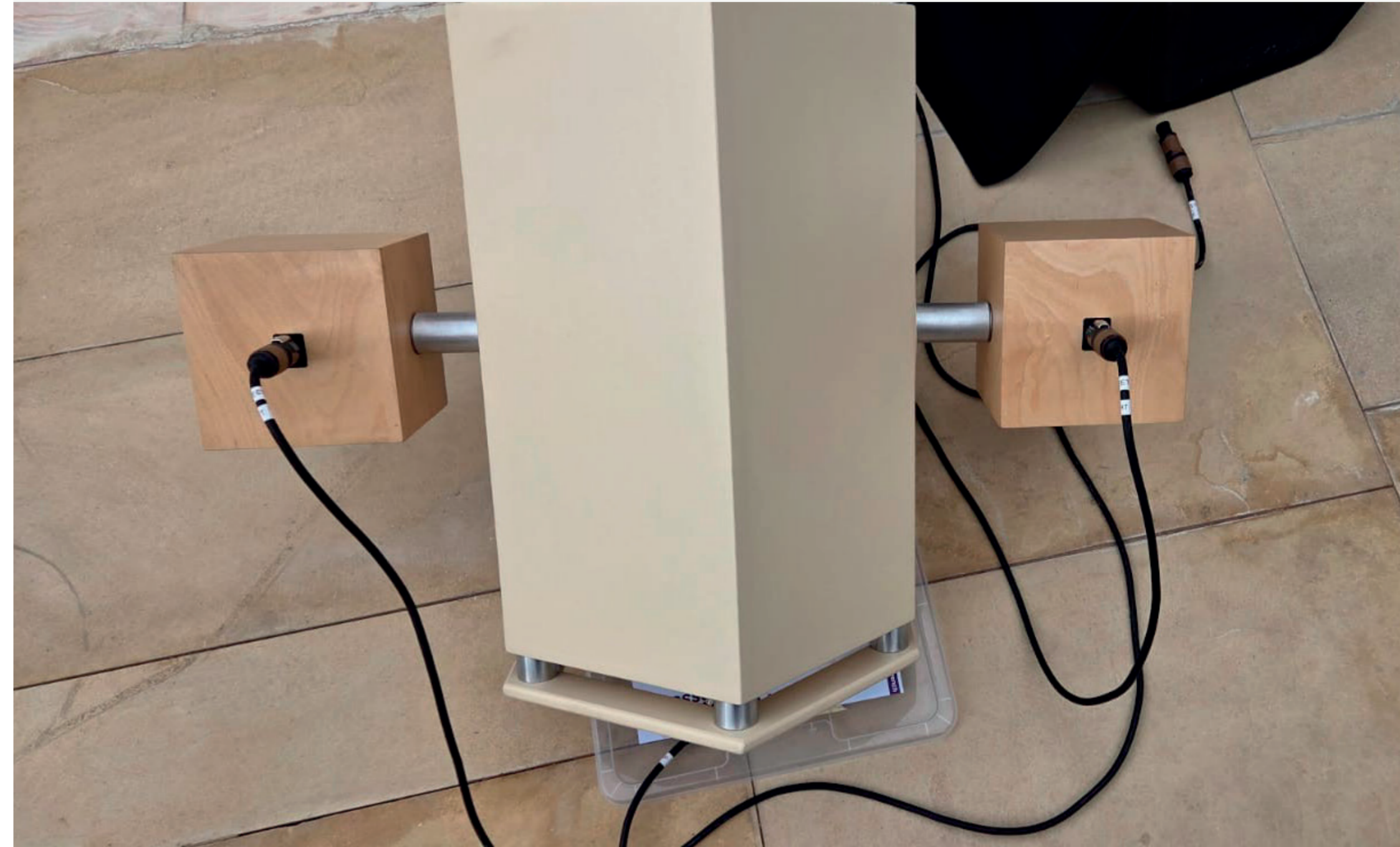

Dimensions with side speakers  
**H 68cm x L 92cm x I 30cm**



Dimensions low speaker  
H 84cm x L 68cm x l 61cm



Dimensions tube to assembly the top speaker onto the low one  
H 10cm



# Solar panels

Dimensions according to plans to be  
verified according to production  
**H 120cm x L 115cm x I 115cm**

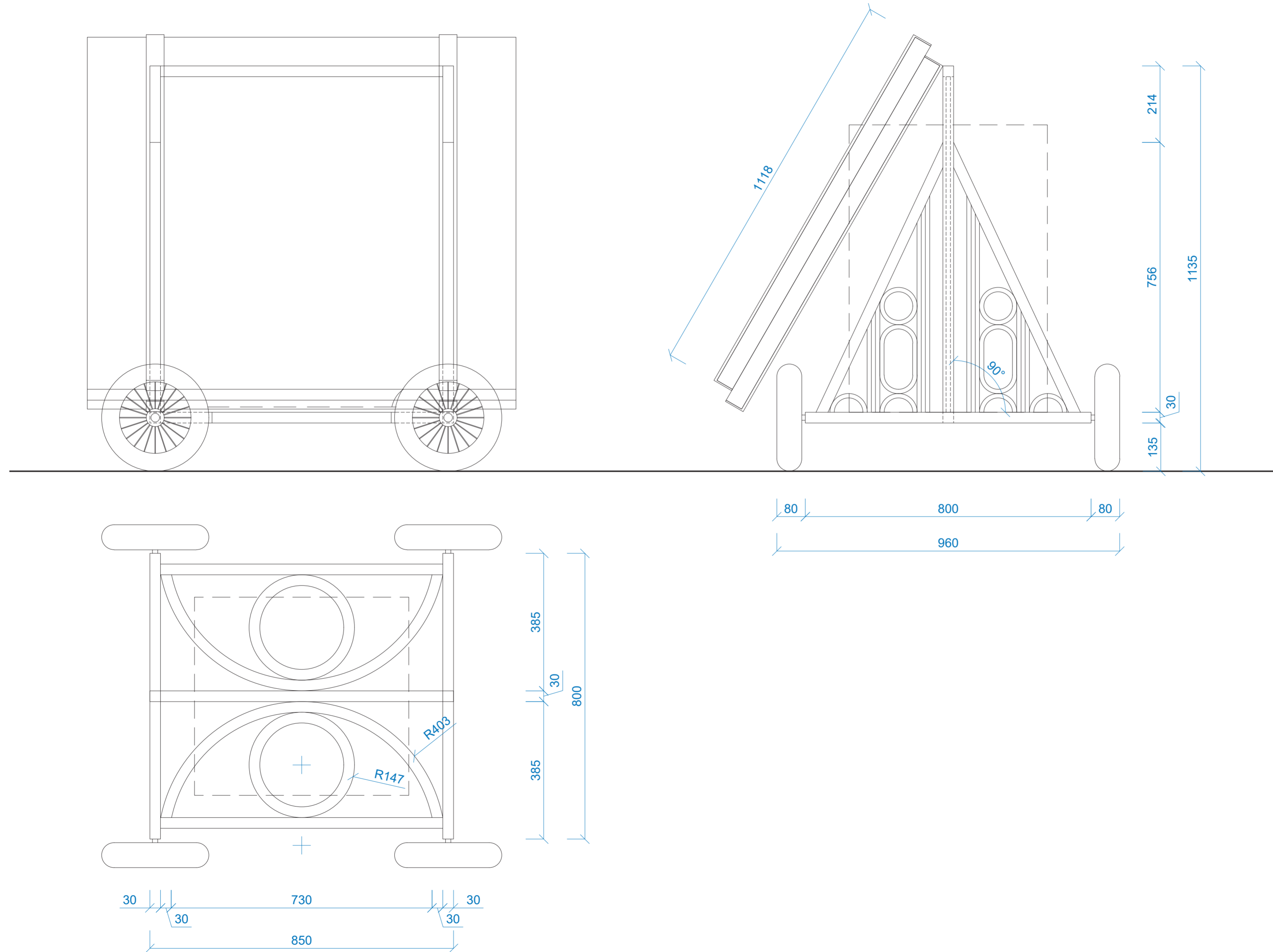



# Trestles

Dimensions

H 71cm x L 50cm x I 48,5cm

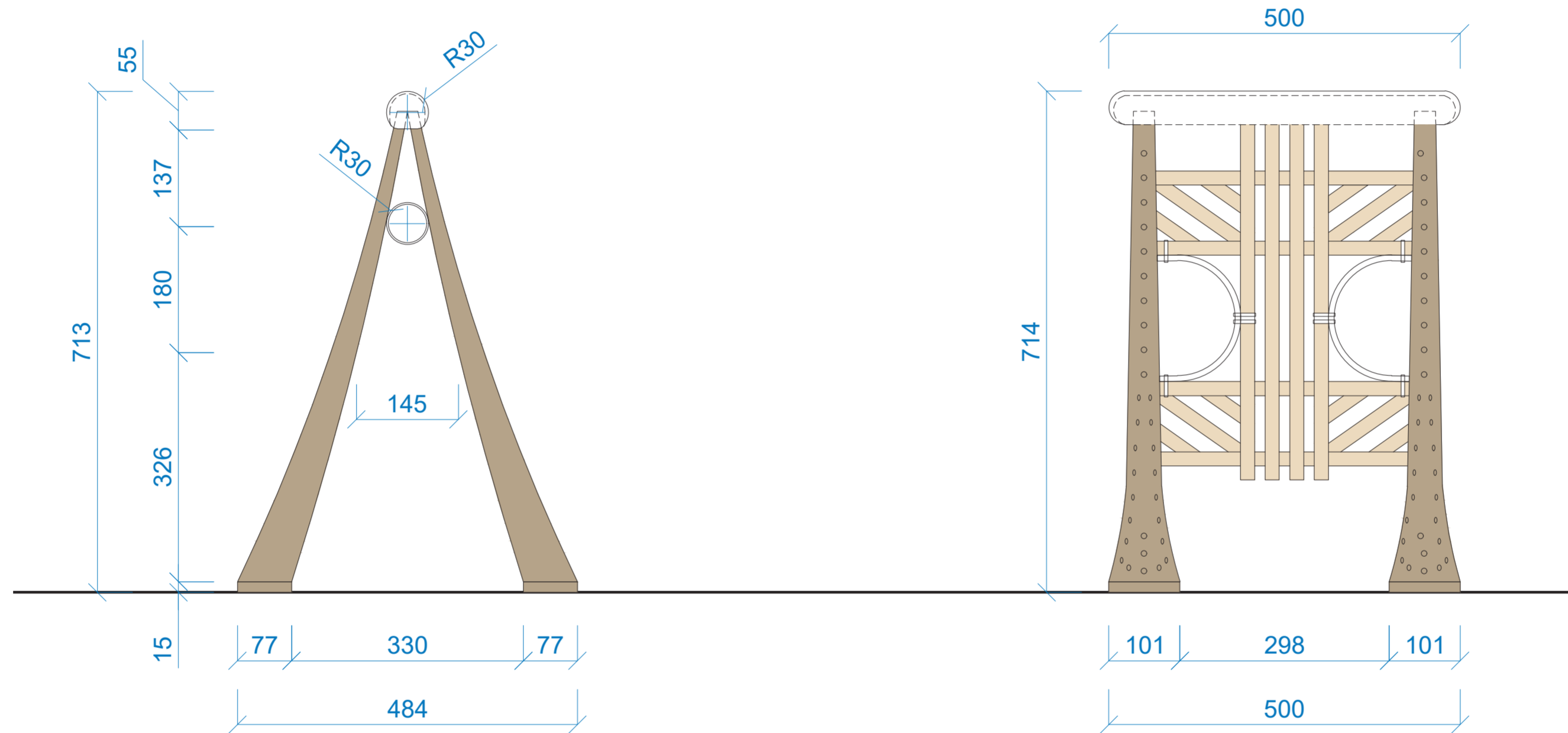





# Mobile storage

Dimensions

H 200cm x L 140cm x I 55cm

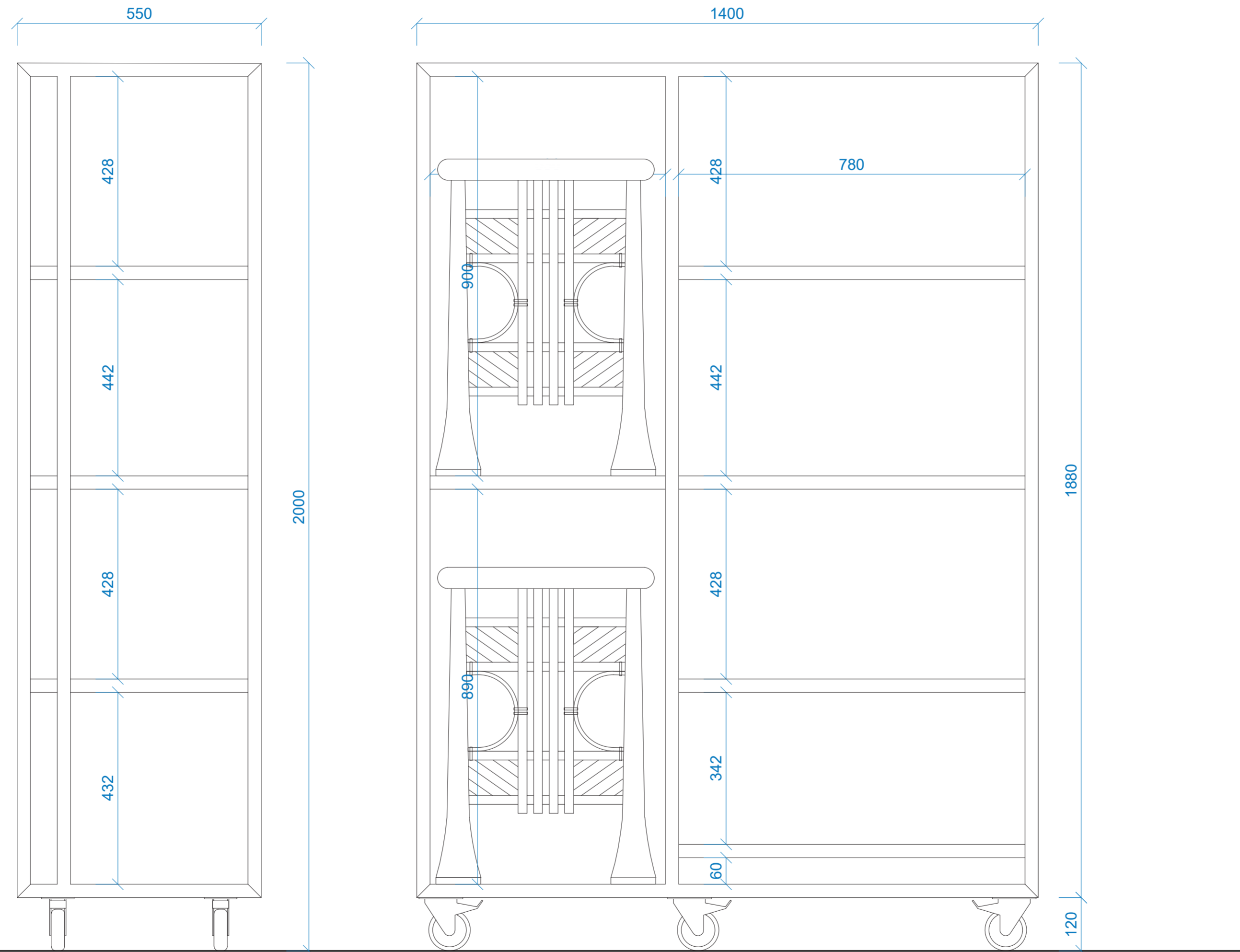





# Mobile lamp

Dimensions  
H 200cm x L 61cm

